

---

## REACH-IN REFRIGERATORS

COR20RRTM, COR22RRTM, COR40RRTMD,  
COR48RRTMD, COR74RRTMT

### Service Manual



Release Date: June 16, 2004

Publication Number: 630460252SER

Revision Date: NA

Revision: A

Visit the IMI Cornelius web site at [www.cornelius.com](http://www.cornelius.com) for all your Literature needs.



# SERVICE MANUAL

The products, technical information, and instructions contained in this manual are subject to change without notice. These instructions are not intended to cover all details or variations of the equipment, nor to provide for every possible contingency in the installation, operation or maintenance of this equipment. This manual assumes that the person(s) working on the equipment have been trained and are skilled in working with electrical, plumbing, pneumatic, and mechanical equipment. It is assumed that appropriate safety precautions are taken and that all local safety and construction requirements are being met, in addition to the information contained in this manual.

To inquire about current revisions of this and other documentation or for assistance with any Cornelius product contact:

**[www.cornelius.com](http://www.cornelius.com)**  
**800-238-3600**

Trademarks and copyrights:

Aurora, Cornelius, Decade, Hydro Boost, Sitco, Spirit, UF-1, Vanguard, Venture, Olympus, and Vista are registered trademarks of IMI Cornelius Inc.

Optifill trademark is pending.

This document contains proprietary information and it may not be reproduced in any way without permission from Cornelius.

Printed in U.S.A.

Copyright © 2004, All Rights Reserved, IMI Cornelius, Inc.



## TABLE OF CONTENTS

Features of the Unit . . . . .	1
Cleaning and Preventive Maintenance . . . . .	2
How Your Cabinet Operates . . . . .	3
Defrost water flow . . . . .	3
Warning light and thermometer . . . . .	3
Temperature control . . . . .	4
Automatic defrosting . . . . .	4
Service Procedures . . . . .	4
Light switches . . . . .	4
Lights . . . . .	5
Temperature controls . . . . .	5
Time clocks . . . . .	6
Blower fan assembly . . . . .	8
Defrost heater . . . . .	8
Condensing unit . . . . .	9
Wiring Diagrams . . . . .	10
COR20RRTM . . . . .	10
COR22RRTM . . . . .	11
COR40RRTMD . . . . .	12
COR48RRTMD . . . . .	13
COR74RRTMT . . . . .	14
Troubleshooting . . . . .	15
Possible causes and solutions . . . . .	15



## FEATURES OF THE UNIT

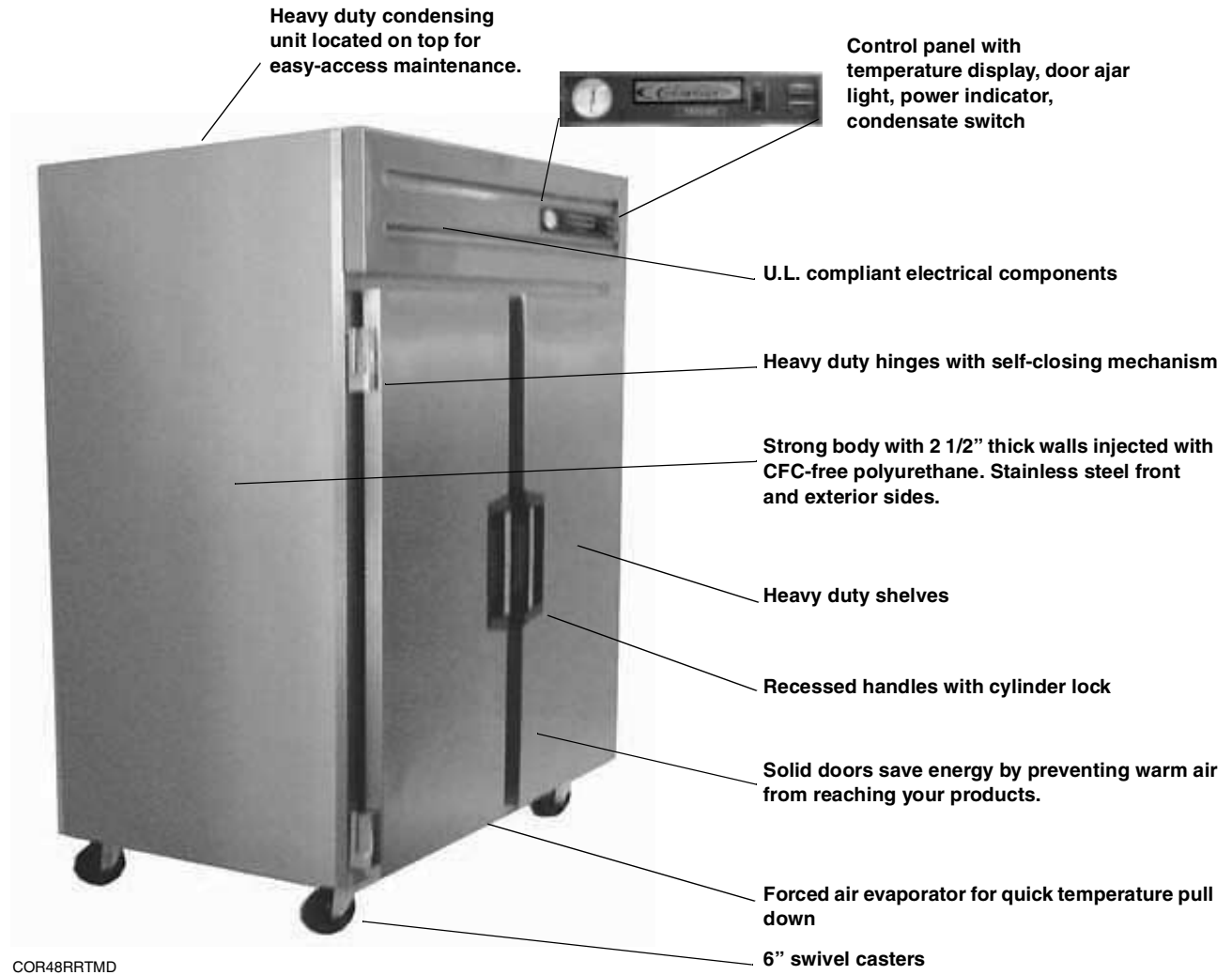

FIGURE 1

## CLEANING AND PREVENTIVE MAINTENANCE

Weekly or sooner, as required:

1. Disconnect the power source before cleaning. Remove all products and place in a proper cooler.
2. Clean the interior and exterior with a mild soap or detergent solution and then rinse with a warm baking soda solution (one cup of baking soda to one gallon of warm water). **Dry the interior completely before replacing products.**
3. Clean the condenser unit periodically by vacuuming the unit compartment, especially the condenser unit coil (it looks like a small auto radiator). If the condenser coil has accumulated dirt and grease (possible in heavy traffic areas or a kitchen), use a strong cleaning solution. If you find any oil in the condensing unit compartment, call a qualified service person immediately.

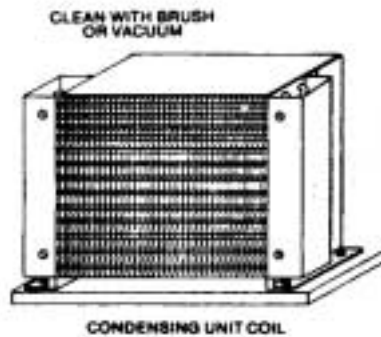

FIGURE 2

4. Empty out and clean drain pan located next to the condensing unit as required. Check regularly for excessive water accumulation.
5. Plug in the cabinet and wait until the proper temperature is achieved before reloading the cabinet with product.

## HOW YOUR CABINET OPERATES



**CAUTION** - Make sure the power supply is turned off before making any electrical repairs.

### Defrost water flow

Your new cabinet is completely self-defrosting. The frost that collects on the concealed coils is automatically removed at predetermined intervals. The defrost water on top-mounted condensing units flows into a thermostatically controlled electric vaporizer where it is dissipated into the atmosphere. All defrost evaporator systems are designed for normal conditions; however, under some conditions, where practical and convenient, a drain line to a floor drain may be preferable to the vaporizer. On base-mounted condensing units, the defrost water flows into the unit compartment and is vaporized by the heat from the hot gas line.

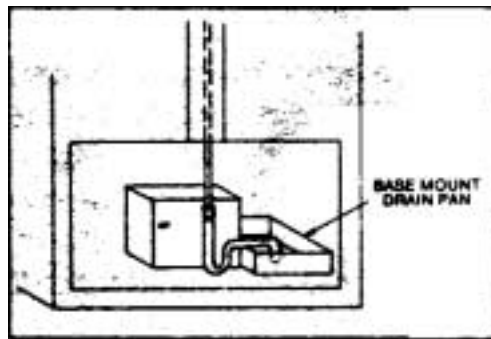

FIGURE 3

### Warning light and thermometer

A fan circulates the cold air from the coil throughout the storage area. This provides uniform temperatures and more rapid recovery after door openings. The number of door openings and the length of time the door is left open should be kept to a minimum to reduce the operating cost and maintain the most efficient operation. The temperature in the cabinet will rise very rapidly whenever the doors are opened; however, the product temperature is not greatly affected.

Some top-mounted cabinets have a thermometer and two small lights located at the right end of the front motor cover grill, directly over the door. One light is green and is always lit when there is power to the cabinet. One light is red and should only be lit when the temperature is above the safe zone. It is controlled by a bi-metallic disk type switch.

The red light will be on at start up until the temperature comes down to normal. When warm product is put in or the doors are held open for a time, the red light may come on but it will go out again as soon as the temperature has recovered. When the doors are closed again, the recovery is very rapid unless a large quantity of warm product is put in at one time.

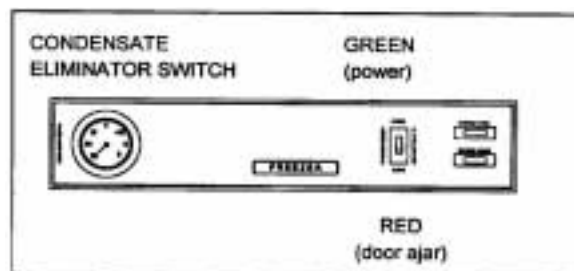

FIGURE 4

## Temperature control

If the condensing unit does not run after the power cord is plugged in, check that the temperature control is in the “on” position. This can be done with an ordinary screwdriver. After the system has operated for several hours, the temperature control may be adjusted to suit your needs. Turn it clockwise to make it colder and counterclockwise to make it warmer. Do not make more than 1/4 turn at one time; then allow it to operate for several hours before making any further adjustment. Once it is set there should be no need to change it.

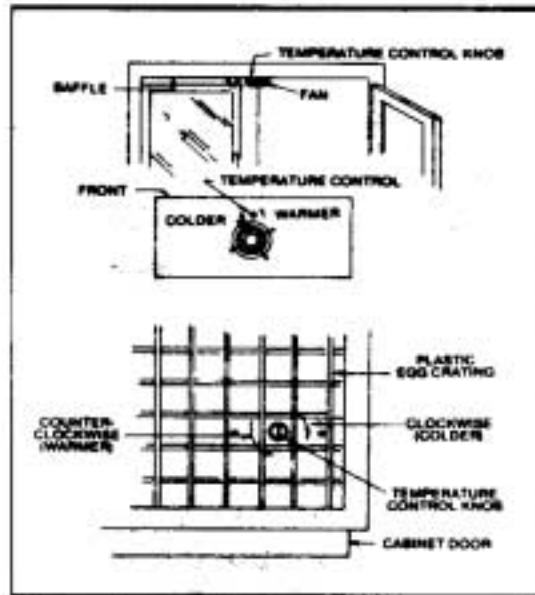

FIGURE 5

After the cabinet has been used for a while, if you should notice any great change in temperature, do not attempt to compensate for it by turning the control. It is much more likely that there is some other problem and a qualified refrigeration service person should be called.

## Automatic defrosting

Normally, when the cabinet storage area temperature is kept at a range of 36°F to 42°F, all refrigerators will defrost the coil during the off cycle (when the compressor is not running). Under some conditions, such as heavy product load or a lot of door openings in a high ambient temperature or excessive relative humidity, it may be advisable to install a time clock which will automatically shut the condensing unit off for an hour or two each night to be sure the coil is completely cleared of frost. It should be connected so the blower fan is left on to speed up the defrosting process. A qualified service person should be consulted before attempting to make these additions.

## SERVICE PROCEDURES



**CAUTION** - Make sure the power supply is turned off before making any electrical repairs.

If any electrical problems arise, a wiring diagram is included with each cabinet to aid in tracing the source of trouble and making the necessary repairs.

## Light switches

Each hinged solid door has a switch which will turn on the interior light whenever the door is opened. In most cases the switch may be examined or exchanged without removing the mounting bracket. Place a knife blade or similar tool behind the switch flange and pry it out. To replace the switch, disconnect the

leads from the terminals and attach them to the new switch and snap it back in place. Make sure there are no breaks or bare wires to cause a short before putting the switch back.

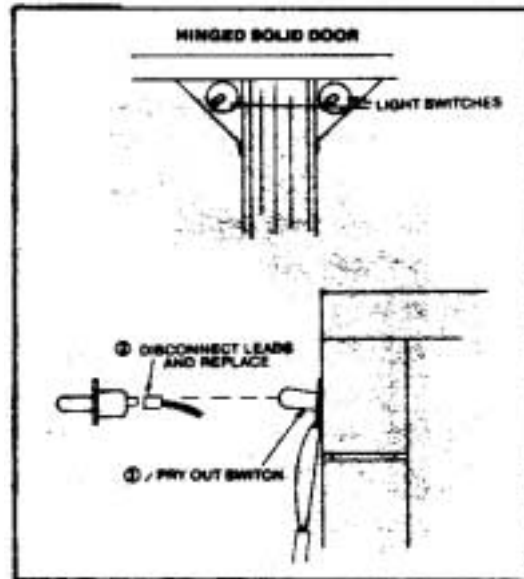

FIGURE 6

## Lights

The incandescent light bulb can be replaced by any 40 watt appliance bulb.

## Temperature controls



**CAUTION** - Make sure the power supply is turned off before making any electrical repairs.

To replace the temperature control:

1. Remove the two mounting screws.

2. Pull the feeler bulb from the well which is usually located on the coil or header and pull the lead wires off the control terminals.

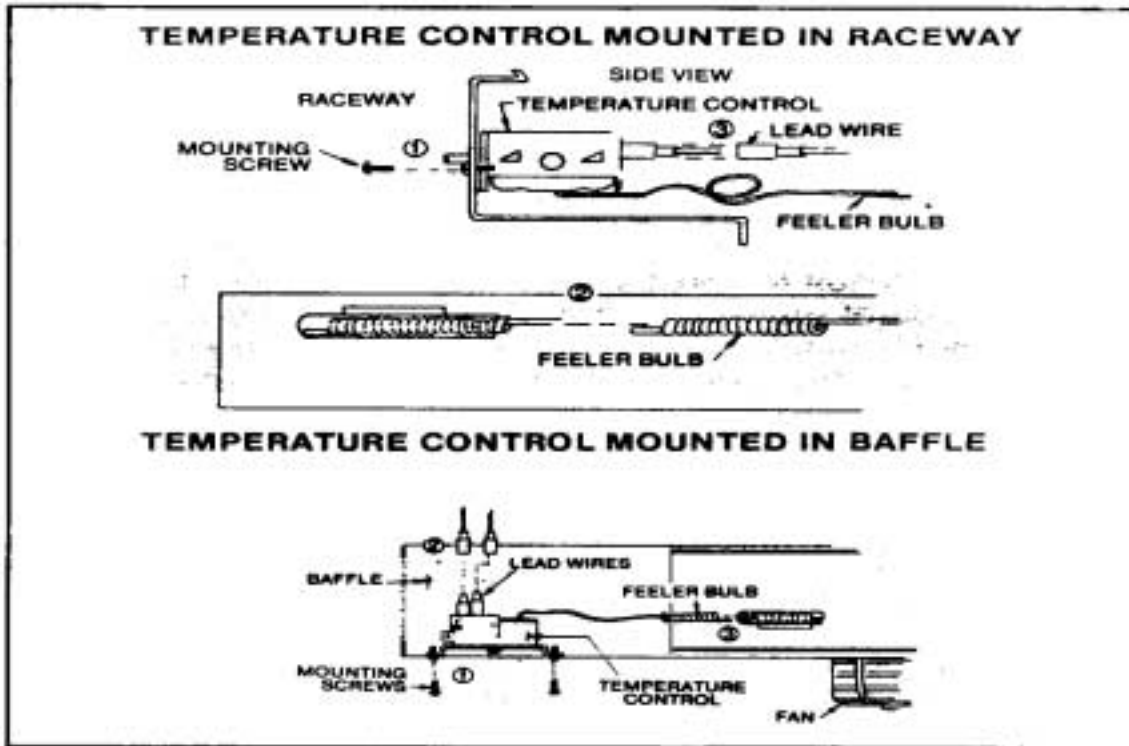

FIGURE 7

If the temperature control is within the first year warranty and is to be returned for credit, be sure to coil the tubing neatly and do not kink it or damage the control in any way. No credit can be issued for any parts that arrive in a damaged condition.

3. Replace the control with an exact factory replacement or one equal to the original specifications. Be sure the feeler bulb is in the proper well and tight. Do not allow the tubing connecting the feeler bulb to the body of the control to touch the coil U bends.

## Time clocks

In the cabinets which have bottom-mounted condensing units, the time clock will be located along the side of the unit. It will be readily visible when the motor cover is removed. The timer is set at the factory for two defrost periods with a fail safe of 40 minutes for both single and multiple door cabinets. (For SAV models the timer is set at the factory for four (4) defrost periods of 30 minutes.) Tests have shown that the factory setting is satisfactory for most applications. However, changes can be made after a sufficient trial period if necessary.

The fail safe is controlled by the small copper pointer on the inner dial. To reset the timer, grasp the knurled knob and turn it counterclockwise until the pointer is at the correct time. As soon as the power is turned on, if the temperature control is in the "on" position, the time clock and condensing unit will start.

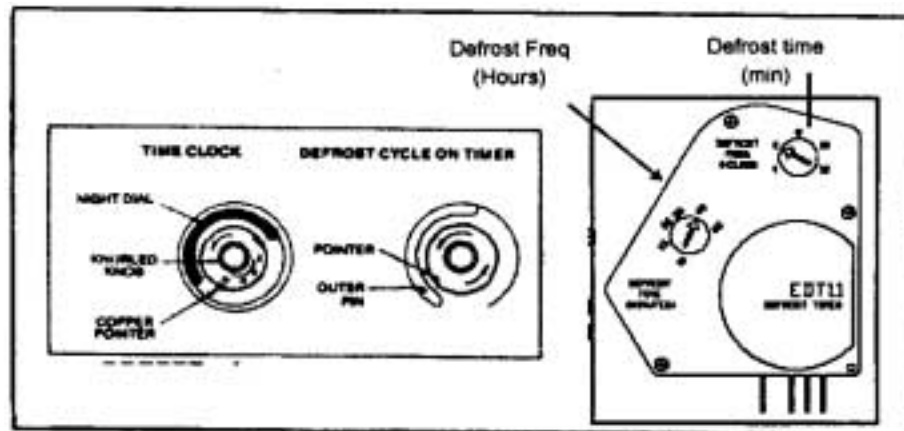

FIGURE 8

When the coil temperature reaches the proper temperature, the fan(s) will automatically start and continue to run until it comes to the defrost cycle. The fan(s) may turn off if the doors are left open too long during a loading period and the coil becomes warm. Do not call for service until the freezer is given enough time to come down to the proper temperature. After the unit is put into operation, the fan(s) will continue to operate until the storage area reaches a proper temperature (recommended average 38°F). The red pilot on the front of the top grill should turn off after about an hour of operation or whenever the sensing element reaches the prescribed temperature. Under some conditions the red warning light may go on at the end of the defrost cycle. However, after the defrost cycle is ended, the temperature should recover in a reasonable length of time and the red light will go out. The defrost periods are set at the factory for 6 a.m. and 6 p.m. and may be changed if needed.

When the pin on the outer dial of the time clock is opposite the pointer, the defrost cycle will start. The condensing unit and the blower fan shut off and the defrost heaters turn on. The heaters are located on the coil. As soon as the coil has reached approximately 50°F and the coil is clear, the combination defrost limit and fan delay switch will trip the timer solenoid and end the defrost cycle to put the system back into the refrigeration cycle. The blower fan will remain off until the coil cools down to 20°F. If the limit switch or solenoid should fail to terminate the defrost cycle, the inner fail safe dial will take over and terminate the defrost cycle when the prescribed time is up. The length of the defrost cycle will vary depending on the type of product stored in the cabinet, the number of door openings, and the atmospheric conditions. The defrost cycle will usually take longer in the summer than in the winter. Before you make changes to the length of the fail safe or the number of defrost periods, a competent service engineer should make a complete study of all the contributing factors.

## Blower fan assembly

To change the fan blade, remove the speed nut from the threaded shaft. If the fan motor must be changed:

1. Remove the fan blade and lay it carefully aside. Be careful not to bend or damage the blade or it will become out of balance.

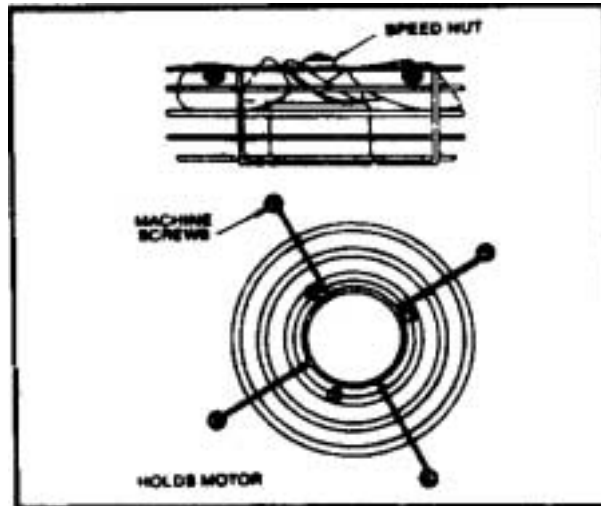

FIGURE 9

2. Remove the four machine screws around the perimeter of the hole in the baffle. These hold the motor mounting bracket in place. The small rubber washers that eliminate vibration should be saved for reassembly.
3. Drop the motor and bracket through the hold.
4. Remove the three machine screws holding the motor to the mounting bracket and disconnect the wire leads.
5. Install the new fan motor and reinstall the fan blade.

## Defrost heater

To change the defrost heater element:

1. Remove the baffle from under the coil. This is the part that catches the condensate water and funnels it down the drain. It also directs the flow of air through the coil and down the air ducts. To remove the baffle, take out the screws and let it down far enough to get to the defrost element.
2. Use a pair of side cutters or diagonal pliers to snip off all of the copper wires holding the heater element to the coil.
3. Disconnect the element from the cabinet leads.

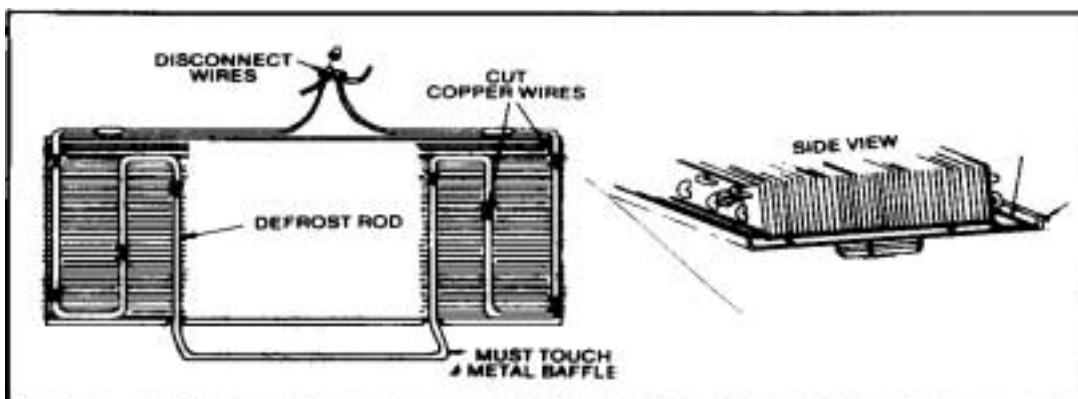

FIGURE 10

4. Install a new heater element. Be sure to use similar copper wire to install the new element tightly against the coil. Note that there is a bend in the heater element along the center rear. This must make good contact with the drain pan or baffle at the drain opening in order to work properly. If it does not make good contact, the drain line will freeze up and the defrost water will overflow into the food compartment during the defrost cycle.

## Condensing unit

The condensing unit consists of the following parts:

- Compressor
- Condenser fan motor assembly
- Condenser
- Relay
- Starting capacitor (running capacitor on some models)
- Service valves. Most units have high and low side service valves, but in some instances there may be only a low side service valve.

Some compressors have the mechanism mounted on springs inside the housing (referred to as internal mounts) and others have the entire compressor body mounted on springs and rubber bushings (referred to as external mounts) to absorb the vibration. In the latter case bolts run up through the springs and are secured with a retainer nut. During shipping the nuts on these bolts are tightened to prevent the compressor from moving and damaging itself or other parts. Before the cabinet is placed in operation, these nuts must be loosened enough to allow the compressor to float freely on the springs so that vibration will be absorbed by the springs.

Problems with the refrigeration system are usually due to failure of one of the components in the condensing unit area. The service person should install a set of gages on the service valves to determine the operating pressures. Compare these pressures to the specifications to determine the cause and solution.

If there is an electrical problem, the service person should use a volt/amp meter, a watt meter, and a continuity tester. An ohm meter can be used as a continuity tester.

A common refrigeration failure is a leak of some or all of the refrigerant. Because the leak can be very small it can be very difficult to find. It usually develops on the high side of the system and only leaks when the compressor is running. The condenser fan carries the refrigerant away making the leak difficult to detect. If a leak detector does not find the leak, put a block of wood or a wad of rags against the fan blade to keep it from turning while the compressor is running. This will cause the pressure to build up and make the leak easier to find. This will not harm the fan motor or system if the fan blade is only stopped for a few minutes.

The pick up hose of the torch should be passed back and forth over all tubing joints and over the entire condenser very carefully. After the leak is found, repair it if possible. If it cannot be repaired, replace the leaking part.

Whenever a leak has been located and repaired, the entire charge should be removed and a triple evacuation procedure must be followed to be sure that all contaminants are removed. A good dryer of proper size should be installed in the liquid line and a new charge of refrigerant put back in allowing extra to compensate for the dryer.

After the cabinet has run for several hours, it should be rechecked to be sure the gas charge is correct and the system is balanced.

# WIRING DIAGRAMS

## COR20RRTM

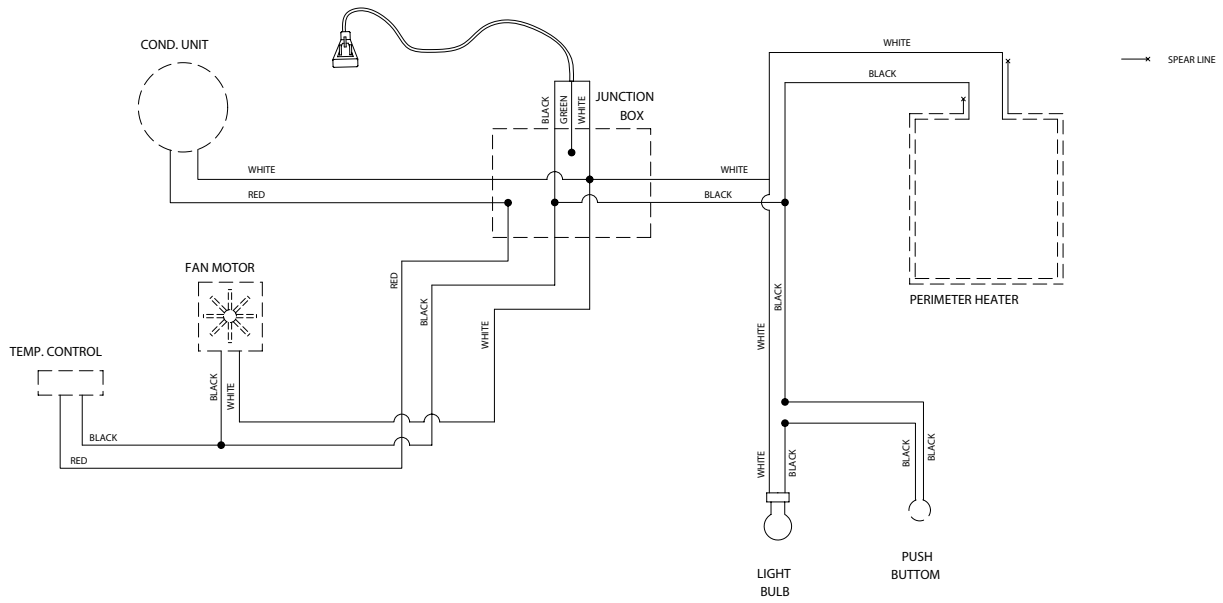
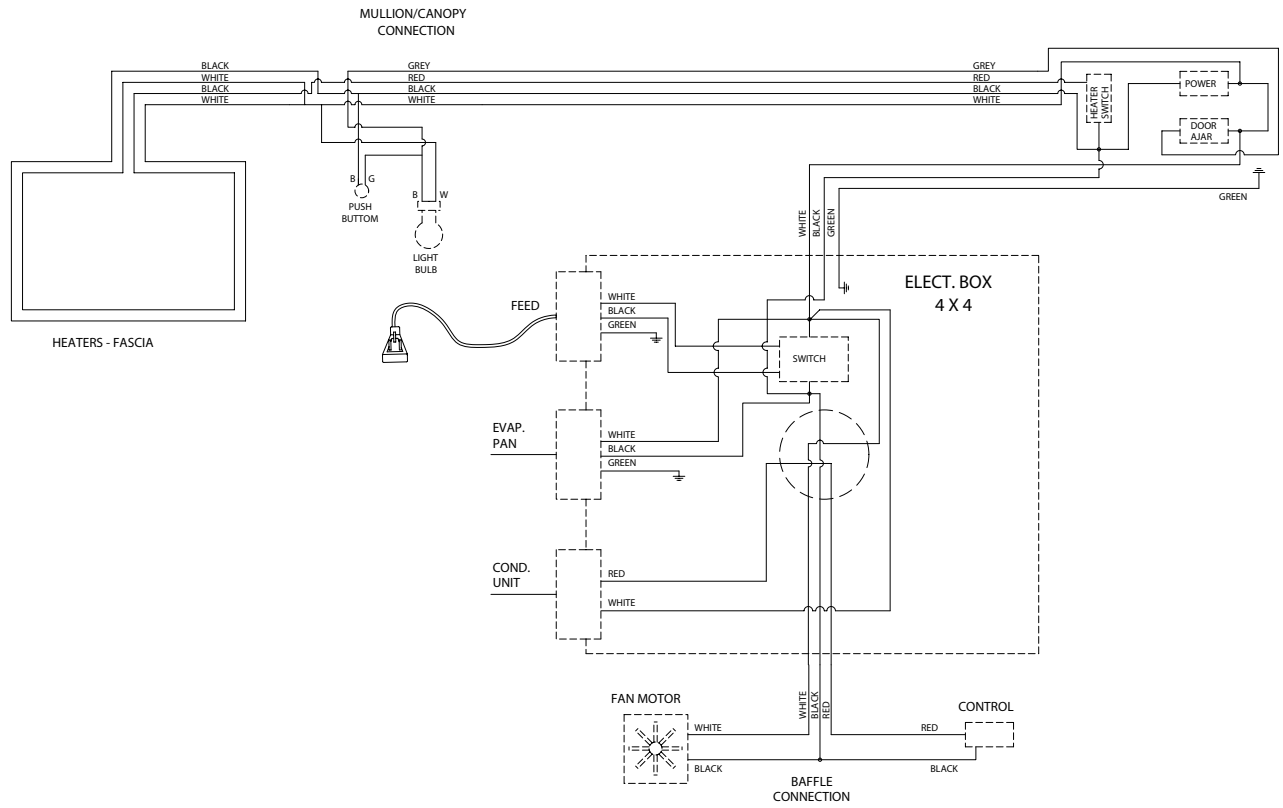

FIGURE 11

**COR22RRTM**



**FIGURE 12**

# COR40RRTMD

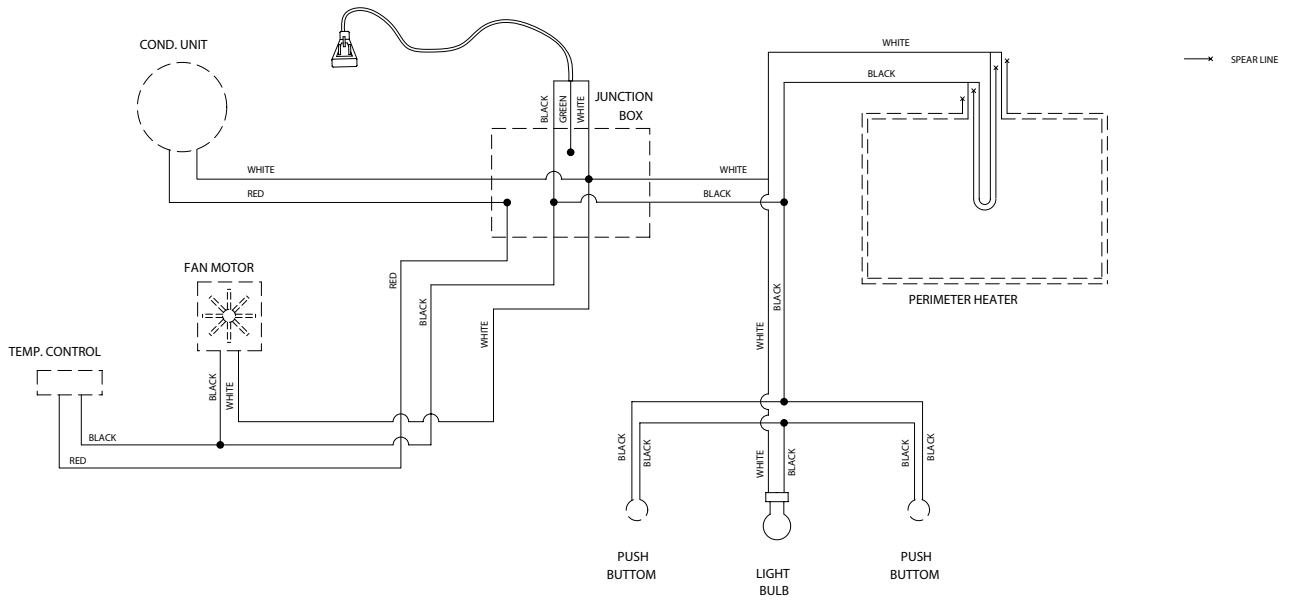
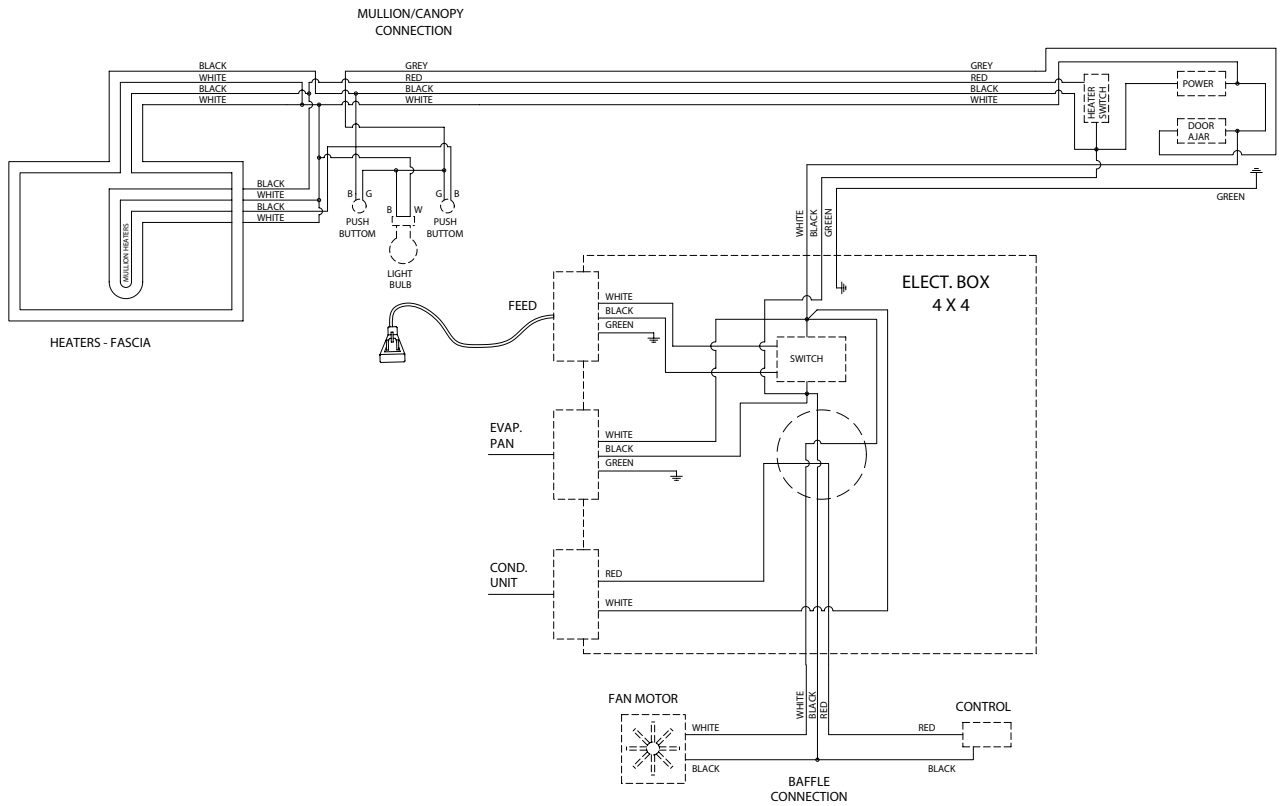

FIGURE 13

**COR48RRTMD**



**FIGURE 14**

**COR74RRTMT**

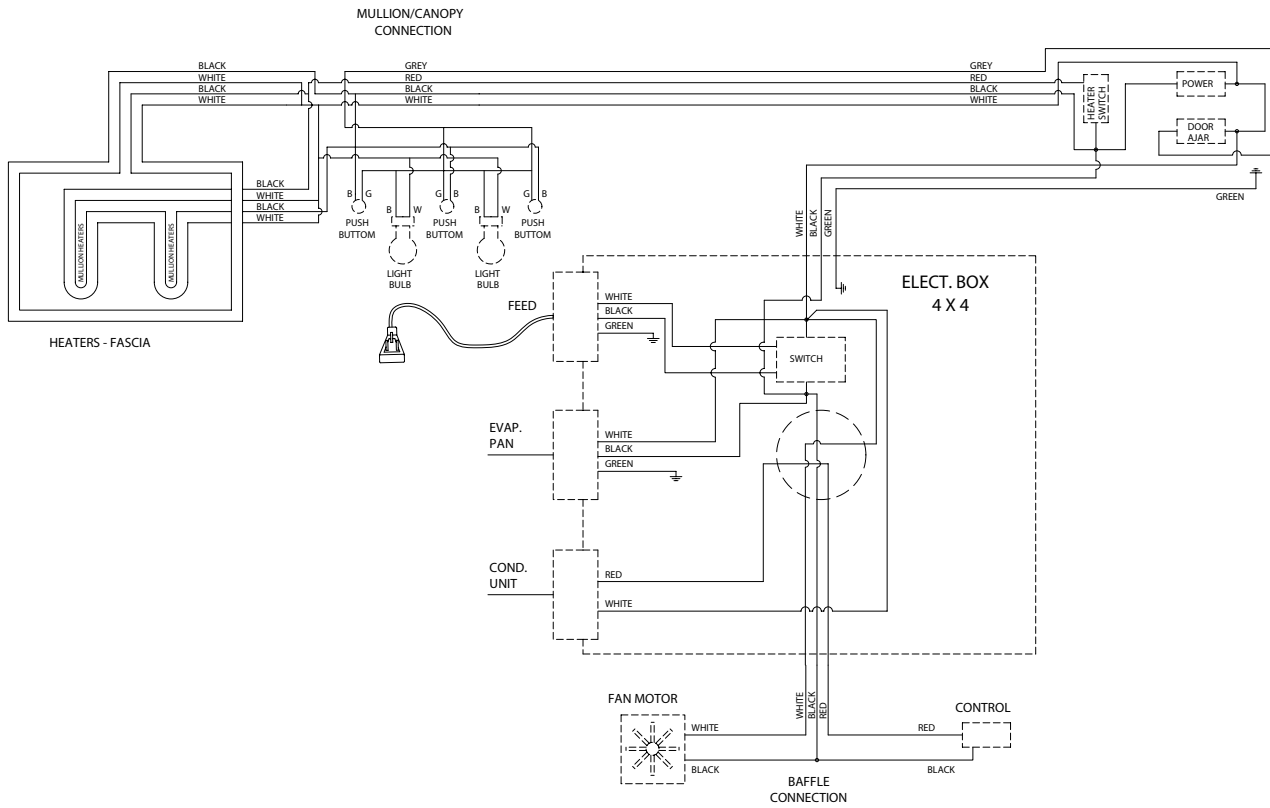

**FIGURE 15**



## TROUBLESHOOTING

### Possible causes and solutions

PROBLEM	POSSIBLE CAUSE	SOLUTION
COMPRESSOR WILL NOT START	No voltage in the electrical socket.	Use a voltmeter to check the voltage.
	The electrical conductor or wires may be cut.	Use an ohmmeter to check for continuity.
	Defective electrical components such as: thermostat, relay, thermal protector, etc.	Replace defective components.
	Thermostat in "off" position.	Turn the thermostat's knob to its maximum position and wait to see if the compressor starts.
	Compressor motor has a winding open or shorted.	Measure the ohmic resistance of the main and auxiliary windings using an ohmmeter. Compare them with the correct values.
	Dirty condenser; lack of air flow.	Clean condenser and allow for air circulation.
	Low voltage.	Use a voltage regulator if the voltage is lower than 103 volts.
	Compressor is stuck.	Change the compressor.
THE TEMPERATURE IS TOO COLD	Temperature control contacts are open.	Repair or replace the contacts.
	Time clock circuits are open.	Determine the reason and repair or replace.
	Incorrect wiring.	Check the wiring diagram and correct.
	Thermostat knob is set at a very cold position.	Set the thermostat knob to a warmer position and check if the compressor stops according to the thermostat's operating range.
	Thermostat does not disconnect the condensing unit.	Check the insulation of the thermostat. If the problem persists, change the thermostat.
	Thermostat capillary bulb is loose or installed improperly.	Correctly fasten the thermostat capillary bulb.
	Control contacts are stuck closed.	File contacts. Change the control. Check amperage load.
Defective or incorrect temperature control.	Determine correct control and replace.	

<b>PROBLEM</b>	<b>POSSIBLE CAUSE</b>	<b>SOLUTION</b>
THE TEMPERATURE IS NOT COLD ENOUGH	Thermostat knob is set at a very warm position.	Set the thermostat knob to a colder position.
	Condenser is dirty.	Clean the condenser.
	The refrigerator has been placed at an inadequate location.	The unit must not be near stoves, walls that are exposed to the sun, or places that lack sufficient air flow.
	Compressor is inefficient or there is a high head pressure due to air in the system.	If there is air in the system, purge and recharge.
	Iced up evaporator coil.	Check temperature control, refrigerant charge, and defrost mechanism. Remove all ice manually and start over.
	Restriction in system.	Locate exact point of restriction and correct.
	The refrigerator has been used improperly.	The shelves must never be covered with any type of plastic or other material that will block the circulation of cold air within the refrigerator.
	Too many door openings.	Advise user to decrease if possible.
	Excessive heat load placed in cabinet.	Advise user not to put in products that are too hot.
	The refrigerator has been overcharged with the refrigerant gas.	Check to see if condensation or ice crystals have formed on the suction line. If so, charge with the correct amount of gas.
	The refrigerant gas is leaking.	Find the location where the gas is leaking in order to seal it or replace the defective component. Change the drier. Perform a good vacuum and recharge the unit.
	The evaporator and/or condenser fans aren't working.	Check the electrical connections and make sure that the fan blade isn't stuck. Replace the fan motor if it doesn't work.
	Low voltage.	Use a voltage regulator if the voltage is lower than 103 volts.
ELECTRICAL SHOCKS	Wires or electrical components are in direct contact with metallic parts.	Check for appropriate insulation on the connections of each electrical component.



PROBLEM	POSSIBLE CAUSE	SOLUTION
NOISE	The refrigerator is not properly leveled.	Check if the noise goes away after you level the refrigerator.
	The condenser is not fastened correctly. Copper tubings are in contact with metal.	While the compressor is working, check to see if metal parts are in contact with one another and/or if the screws that fasten the condenser are tightened.
	The evaporator and/or condenser fans are loose.	Check if the fans are securely fastened. Also, check if the fan blades are loose, broken or crooked. If so, change the faulty blade.
	Compressor has an internal noise.	If the noise persists after all other measures have been taken, it may be originating from the compressor.
EXTREME CONDENSATION INSIDE THE REFRIGERATOR	Thermostat knob is set at a very cold position.	Set the thermostat knob to a warmer position and check if the compressor stops according to the thermostat's operating range.
	The outside environment's relative humidity is very high (over 75%).	This type of occurrence is caused by local climatic conditions and not by the refrigerated unit.
	The refrigerator door won't shut completely.	Check the door and/or the magnetic gasket. Adjust the door hinges if needed; replace the gasket if broken.
	The refrigerator has been placed at an inadequate location.	The unit must not be near sources that produce too much heat.
NO ILLUMINATION	The light switch is in "off" position.	Press the light switch to the "on" position.
	False contact on the light switch, the fluorescent tube, or the ballast.	Inspect all connections.
	Light switch, ballast and/or fluorescent tube are damaged.	Replace the damaged component.

**IMI Cornelius Inc.**  
**[www.cornelius.com](http://www.cornelius.com)**